

DETACHED RESIDENTIAL GARAGE - REQUIREMENTS FOR BUILDING PERMIT

Building a Detached Garage?

Before submitting a building permit application please be aware of the following:

- + A residential permit is required.
- + Two sets of building plans **drawn to scale** (1/4" = 1' scale is preferred) need to be submitted. Plans shall be no smaller than 8.5" x 11" paper and no larger than 24" x 36".
- + Seven plot plans (include all existing structures, proposed location of the detached garage, and setbacks from all property lines to the proposed detached garage) are required. (See plot plan handout for more details.)
- + Building plans must include a roof framing plan, section plan, and elevation details. Foundation plans must be provided as well.

An engineered foundation plan may be required based on the location and/or design of the garage. If engineered foundation plans are required, two original wet stamped plans must be submitted with all detailed drawings.

- + All monolithic foundations greater than 24'-0' in width (truss length) shall be designed by a Colorado Registered Engineer.
- + Size, spacing, specifications of studs, rafters, beams, ridge board or ridge beam, collar ties, and top and bottom plates must be specified.



DETACHED GARAGE - REQUIREMENTS FOR BUILDING PERMIT

ROOF FRAMING AND PLAN VIEW

INDICATE TYPE OF ROOF SYSTEM & SPACING OF RAFTERS OR TRUSSES

INDICATE HEADER SIZES FOR ALL OPENINGS

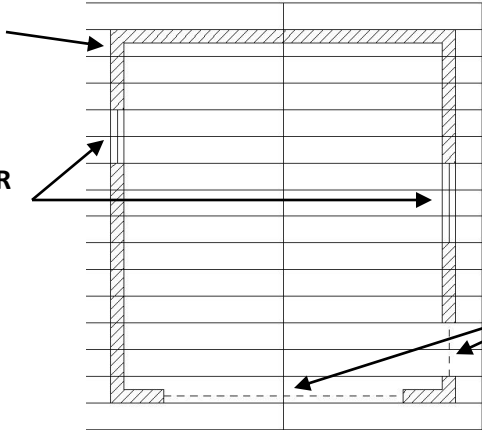

NOTE: GARAGE LENGTH NOT TO EXCEED TWICE ITS WIDTH OR ENGINEERING WILL BE REQUIRED

SHOW LOCATION OF ALL OPENINGS

BUILDING SECTION

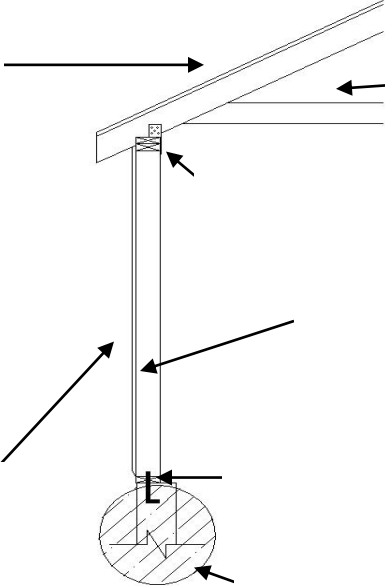

RAFTER COLLAR TIES ARE TO BE LOCATED IN LOWER 1/3 OF ROOF PITCH IF RIDGE BOARD IS USED

PROVIDE WIND BRACING AT ALL CORNERS AND EVERY 25' OF WALL. SEE SECTION R602.10 OF THE 2015 IRC FOR MORE INFORMATION ON WALL BRACING AND GARAGE DOOR PORTAL FRAMING.

Single Family Residential One Story Detached Garage

Note: For roofs with slopes less than 4:12, follow manufacturer's instructions for low slope application of roofing material.

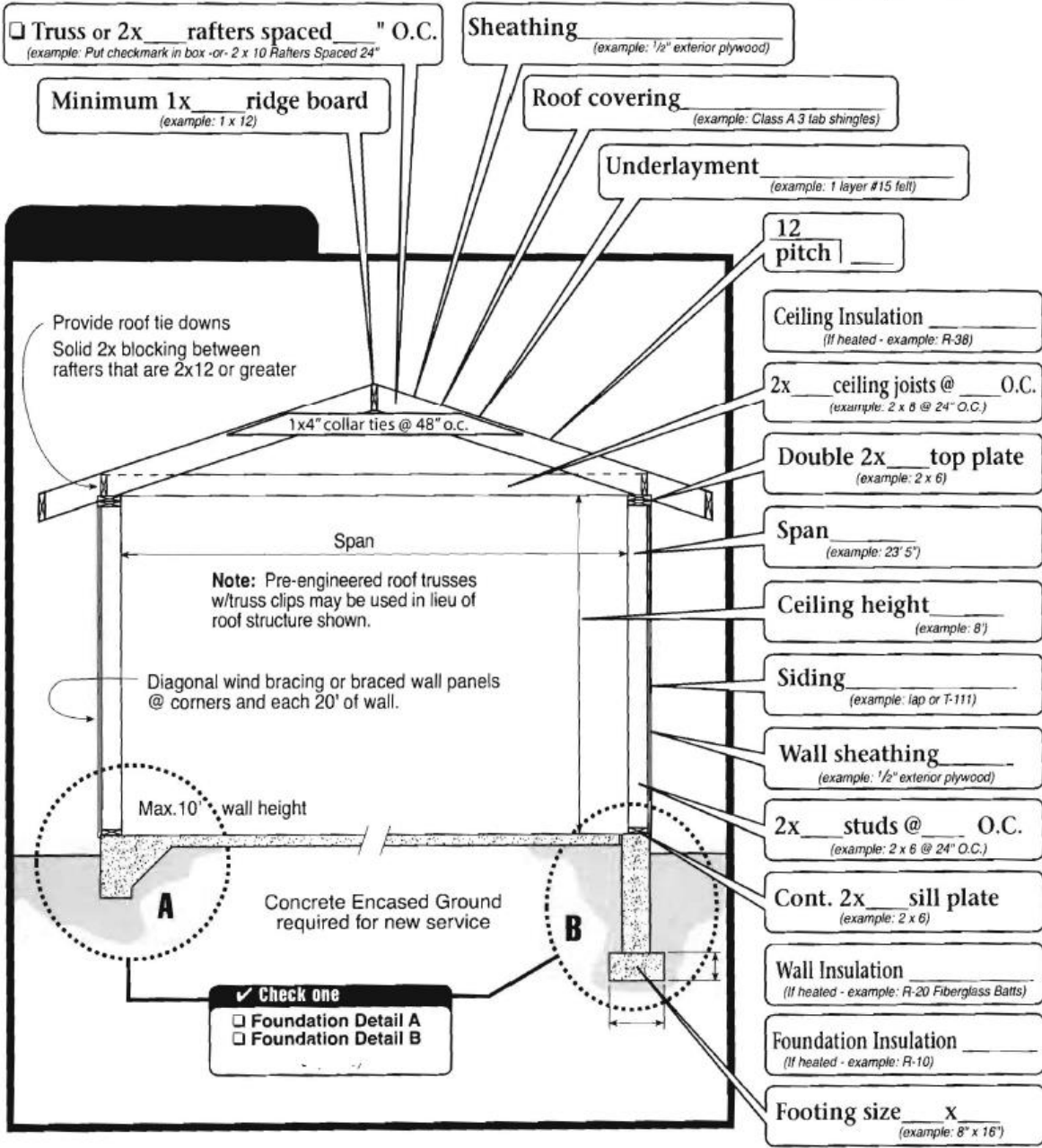

This handout was developed by the Colorado Chapter of the International Code Council as a basic plan submittal under the 2012 International Residential Code. It is not intended to cover all circumstances. Check with your Department of Building Safety for additional requirements.